

**CITY OF PRAIRIE DU CHIEN**

214 East Blackhawk Avenue - PO Box 324 - Prairie du Chien, WI 53821 \* Phone: (608) 326-6406 \*  
Fax: (608) 326-6407 \* [www.cityofpdc.com](http://www.cityofpdc.com)

Notice is hereby given according to State Statutes that the **COMMON COUNCIL** of the City of Prairie du Chien will meet on **Tuesday, March 20, 2018 at 7:00 P.M.** in the Council Chambers of City Hall. *PROOF OF POSTING AFFIDAVIT:* This agenda was posted more than 24 hours prior to the start of this meeting as follows: City Hall, 214 E. Blackhawk Avenue (kiosk) - Library, 720 S. Wacouta Avenue - U.S. Post Office, 120 S. Beaumont Rd. - Mailed & emailed to Members - News media as requested

**MEETING NOTICE – COMMON COUNCIL**

**Date: Tuesday, March 20, 2018**

**Time: 7:00 P.M.**

**Location: Council Chambers**

**ITEMS TO BE ACTED UPON:**

1. Call to order/Roll Call.
2. Certification of the open meeting law agenda requirements and approval of the agenda
3. Pledge of Allegiance

**4. PUBLIC HEARINGS**

- A. Public Hearing on Ordinance 2018-04 to re-zone property located on South First Street commencing on the West side of First Street, according to the Plat of Lower Prairie du Chien, 209 feet North of the South line of Farm Lot Number Thirty-five (35), thence South 80° West 99 feet, thence North 10° West 75 feet, thence North 80° East 99 feet to the line of First Street, thence along the line of said First Street 75 feet to the place of beginning, the above described lot being 75.00 feet front on the West side of First Street and running back 99.00 feet and being parcel #12-271-2322-0000 to be re-zoned from "R-1 Low Density Residential District" to "B-2 Highway Commercial District." (Petition to rezone made by the Trustees of Prairie du Chien Aerie Number 1502 of the Fraternal Order of Eagles for the purpose of constructing a new Eagles Club. City Plan Commission voted to recommend approval of the rezoning at its February 26, 2018 meeting.)
- B. Action on Aforesaid Item - Ordinance 2018-04 AMENDING THE ZONING ORDINANCE OF THE MUNICIPAL CODE OF THE CITY OF PRAIRIE DU CHIEN, CRAWFORD COUNTY, WISCONSIN. The purpose of this Ordinance is to re-zone property located on South First Street in the City of Prairie du Chien.

**5. CONSENT AGENDA:**

- A. COUNCIL – March 6, 2018
- B. FINANCE – March 6, 2018
- C. PUBLIC WORKS – March 6, 2018
- D. PERSONNEL – March 6, 2018
- E. OPERATORS LICENSES

(Note: These items may be approved on a single motion and vote due to their routine nature or previous discussion. Please indicate to the Mayor if you would prefer separate discussion and action.)

**6. ITEMS REMOVED FROM CONSENT AGENDA**

**7. CITIZENS' COMMENTS, RESOLUTIONS AND PRESENTATIONS**

**8. CITY ADMINISTRATOR'S REPORT**

**9. MAYOR'S REPORT**

**10. COMMITTEE REPORTS AND ACTIONS**

**A. FINANCE**

1. DISCUSSION AND ACTION: Claims

**B. Public Works**

1. DISCUSSION AND ACTION: Street Superintendent drafted a memo to repair a storm sewer on South Main and West Wisconsin Street. WDOT is sharing costs on the repair.
2. DISCUSSION AND ACTION: Street Superintendent requesting for Bid Letting for Bituminous Paving and Miscellaneous Curb and Gutter plus Sidewalk Replacement.

**11. NEW BUSINESS (Including items for future agenda consideration or Committee assignment)**

**A. DISCUSSION AND ACTION** – Selection of a proposal for performing mussel survey for the Villa Louis Boat Landing project. This is a mandatory step that needs to be performed per WIDNR. A memo is included in the packet.

**B. DISCUSSION** – Marquette Road project is expected to start April 2 a time line for the work is included in the packet. The City will host a pre-construction meeting open to public and businesses the week of March 26-30. At the time of drafting agenda the exact date was not determined.

**12. ADJOURN TO CLOSED SESSION**

**A. Under Wisconsin State Statute 19.85 (1) (e)** Deliberating or negotiating the purchasing of public properties, the investing of public funds, or conducting other specified public business, whenever competitive or bargaining reasons require a closed session. R.E. - Possible Land Sale (Woodridge Acres).

**B. Under Wisconsin State Statute 19.85 (1) (g)** Conferring with legal counsel for the governmental body who is rendering oral or written advice concerning strategy to be adopted by the body with respect to litigation in which it is or is likely to become involved. R.E. - Claim against the City.

**C. Under Wisconsin State Statute 19.85(1) (c).** Considering employment, promotion, compensation or performance data of any public employee over whom the governmental body has jurisdiction or exercises responsibility R.E. – Waste Water Superintendent.

**13. CONVENE INTO OPEN SESSION**

**14. ACTION FROM OPEN SESSION**

**15. ADJOURNMENT**



Chad Abram, Interim City Administrator

**NOTE: The next regularly scheduled Council meeting will be Tuesday, April 10, 2018.**

# ORDINANCE 2018-04

\* \* \*

## AMENDING THE ZONING ORDINANCE OF THE MUNICIPAL CODE OF THE CITY OF PRAIRIE DU CHIEN, CRAWFORD COUNTY, WISCONSIN

---

**Purpose:** The purpose of this Ordinance is to re-zone property located on South First Street in the City of Prairie du Chien.

---

The Common Council of the City of Prairie du Chien, Crawford County, Wisconsin, does ordain as follows:

**Section 1:** That the parcel of land in the City of Prairie du Chien, Crawford County, Wisconsin, described as follows:

Commencing on the West side of First Street, according to the Plat of Lower Prairie du Chien, 209 feet North of the South line of Farm Lot Number Thirty-five (35), thence South 80° West 99 feet, thence North 10° West 75 feet, thence North 80° East 99 feet to the line of First Street, thence along the line of said First Street 75 feet to the place of beginning, the above described lot being 75.00 feet front on the West side of First Street and running back 99.00 feet and being parcel #12-271-2322-0000

be re-zoned from "R-1 Low Density Residential District" to "B-2 Highway Commercial District."

**Section 2:** Any Ordinance, or parts thereof, inconsistent herewith are hereby repealed.

**Section 3:** This Ordinance shall be published as required by law after passage by the Common Council.

Passed and approved this 20th day of March, 2018.

---

David Hemmer, Mayor

ATTEST:

---

Chad Abram, City Administrator

\* \* \*

Certification

I, Tina Fuller, am the duly qualified and acting City Clerk of the City of Prairie du Chien, Crawford County, Wisconsin. I hereby certify that the aforementioned is a true and exact reproduction of the original ordinance or resolution adopted by the Common Council.

IN WITNESS WHEREOF, I have executed this Certificate in my official capacity  
on \_\_\_\_\_ day of March, 2018.

(SEAL)

---

Tina Fuller  
City Clerk

## MINUTES OF THE COMMON COUNCIL– March 6, 2018

A regular meeting of the City of Prairie du Chien Common Council was held on Tuesday, March 6, 2018 at 7:00 P.M. in City Hall. Mayor Dave Hemmer called the meeting to order.

### ITEMS TO BE ACTED UPON:

1. Call to Order & Roll Call – Hayes-Hall Absent
2. Certification of the Open Meeting Law Agenda Requirements and Approval of the Agenda – Motion: Solomon Second, Olson, Vote: 7-0.
3. Pledge of Allegiance – led by City Clerk Todd Crotty.

### 4. PUBLIC HEARINGS

A. Public Hearing on the vacation of the alley located in Block 142 of the Union Plat in the City of Prairie du Chien, Crawford County, Wisconsin. Council President Gilberts opened the public hearing at 7:03 P.M. City Planner Garth Frable gave an overview of the vacation. President Gilberts closed the public hearing at 7:04 P.M.

B. Action on Aforesaid Item - Resolution 2018-07 Vacating the alley located in Block 142 of the Union Plat in the City of Prairie du Chien, Crawford County, Wisconsin. Action: to approve Resolution 2018-07. Motion: Solomon, Second: Myers, Vote: 7-0.

C. Public Hearing Amending Section 7.0 (Nonconforming Uses, Structures and Lots), Section 8.0 (Conditional Uses), Section 10.0 (Board of Zoning Appeals), and Section 12.0 (Definitions) of Chapter 17 (Zoning Code) of the Municipal Code of the City of Prairie du Chien, Crawford County, Wisconsin, To Ensure Compliance and Consistency with Wisconsin State Statutes (the City Plan Commission voted to recommend the changes at its January 15, 2018 meeting). Council President Gilberts opened the public hearing at 7:05 P.M. City Planner Garth Frable gave an overview of the changes in the ordinance to conform with state law. President Gilberts closed the public hearing at 7:11 P.M.

D. Action on Aforesaid Item - Ordinance 2018-03 Amending Section 7.0 (Nonconforming Uses, Structures and Lots), Section 8.0 (Conditional Uses), Section 10.0 (Board of Zoning Appeals), and Section 12.0 (Definitions) of Chapter 17 (Zoning Code) of the Municipal Code of the City of Prairie du Chien, Crawford County, Wisconsin, To Ensure Compliance and Consistency with Wisconsin State Statutes. Action: Adopt Ordinance 2018-03. Motion: Solomon, Second Gilberts, Vote: 7-0.

### 5. CONSENT AGENDA:

- A. COUNCIL – February 27, 2018
- B. FINANCE – February 27, 2018
- C. PERSONNEL – February 27, 2018
- D. PUBLIC WORKS – February 27, 2018
- E. PPOLICE AND FIRE – January 31, 2018
- F. OPERATORS LICENSES (if any)

(Note: These items may be approved on a single motion and vote due to their routine nature or previous discussion. Please indicate to the Mayor if you would prefer separate discussion and action.)

Action: To approve the consent agenda. Motion: Gilberts, Second, Solomon, Vote: 6-0.

### 6. ITEMS REMOVED FROM CONSENT AGENDA –

None

### 7. CITIZENS' COMMENTS, RESOLUTIONS AND PRESENTATIONS

### 8. CITY ADMINISTRATOR'S REPORT

Abram informed the council on the \$30,000.00 donation from the Bremer Foundation. The favorable ruling from the Office of the Commissioner of Railroads reference the Villa Louis Boat Landing Crossing. The Public hearing will be on March 21<sup>st</sup> 10:00 A.M. at City Hall. City Wide Clean up April 9-11. March 8<sup>th</sup> RFP due for the Marina. Marquette Road still planning on starting April 1<sup>st</sup>.

### 9. Mayor's Report

## **10. COMMITTEE REPORTS AND ACTIONS**

### **A. FINANCE**

1. DISCUSSION AND ACTION: Claims – Action: to approve the claims. Motion: Gilberts, Second: Solomon, Vote: 7-0.

### **B. PUBLIC WORKS**

1. DISCUSSION AND ACTION – PSA with Vierbecher for Marquette Road Construction Phase 2 and Villa Louis Boat Landing. A memo is included in the packet as well as a copy of the PSA. Action: To agree to PSA with Vierbecher Marquette Road Construction Phase 2 and Villa Louis Boat Landing. Motion: Myers, Second, Crotty, Vote: 7-0.
2. DISCUSSION AND ACTION – Establishing ATV/UTV routes within the City of Prairie du Chien. Postponed to future meeting.

## **11. NEW BUSINESS (Including items for future agenda consideration or Committee assignment)**

### **12. ADJOURN TO CLOSED SESSION (7:53 PM)** Motion: Solomon, Second, Olson, Vote: 7-0.

- A. Under Wisconsin State Statute 19.85 (1) (e) Deliberating or negotiating the purchasing of public properties, the investing of public funds, or conducting other specified public business, whenever competitive or bargaining reasons require a closed session. RE: Possible Land Sale (Woodridge Acres).
- B. Under Wisconsin State Statute 19.85 (1) (g) Conferring with legal counsel for the governmental body who is rendering oral or written advice concerning strategy to be adopted by the body with respect to litigation in which it is or is likely to become involved. RE: Zoning Enforcement.

### **13. CONVENE INTO OPEN SESSION (8:48 PM)** Motion: Solomon, Second, Olson, Vote: 7-0.

### **14. ACTION FROM OPEN SESSION**

- A. To propose counteroffer for Lot 21 at Woodridge Acres. Motion: Solomon, Second, Gilberts, Vote: 7-0.
- B. To have camper moved by March 31, 2018 or pursue litigation. Motion: Gilberts, Second, Myers, Vote: 6-0-1. Jones abstained.

### **15. ADJOURNMENT (8:53 PM)** Motion: Gilberts, Second Solomon, Vote: 7-0.

---

**Chad Abram, Interim City Administrator**

**Resolutions Passed: Resolution 2018-07 Vacating the alley located in Block 142 of the Union Plat in the City of Prairie du Chien, Crawford County, Wisconsin.**

**Ordinances Passed: Ordinance 2018-03 Amending Section 7.0 (Nonconforming Uses, Structures and Lots), Section 8.0 (Conditional Uses), Section 10.0 (Board of Zoning Appeals), and Section 12.0 (Definitions) of Chapter 17 (Zoning Code) of the Municipal Code of the City of Prairie du Chien, Crawford County, Wisconsin, To Ensure Compliance and Consistency with Wisconsin State Statutes.**

## **MINUTES OF THE FINANCE COMMITTEE – March 6, 2018**

A meeting of the City of Prairie du Chien Finance Committee was held on Tuesday, March 6, 2018 at 6:54 P.M. in City Hall. Nate Gilberts, Chairperson called the meeting to order.

### **GENERAL ITEMS TO BE ACTED UPON**

1. Call to Order & Roll Call – Present: Nate Gilberts, Karen Solomon, Heather Olson and Ron Leys. City Staff also present, Mayor Dave Hemmer, City Administrator Chad Abram
2. Certification of the Open Meeting Law Agenda Requirements and Approval of the Agenda – Motion: Solomon, Second: Gilberts, Vote: 4-0.
3. Approval of the minutes of the February 27, 2018 meeting. Motion: Solomon, Second: Olson, Vote: 4-0.

### **ACTION ITEMS**

4. Discussion and Action: Claims – Action: To pay our bills. Motion: Gilberts, Second Olson, Vote: 4-0.
5. ADJOURNMENT – Motion Solomon, Second, Gilberts, Vote: 4-0. (6:57 PM)

Submitted by Chad Abram, Interim City Administrator

## **MINUTES OF THE PUBLIC WORKS COMMITTEE – March 6, 2018**

A meeting of the City of Prairie du Chien Public Works Committee was held on Tuesday, March 6, 2018 at 6:22 P.M. in City Hall. Chairperson Todd Myers called the meeting to order.

### **GENERAL ITEMS TO BE ACTED UPON**

1. Call to order/Roll Call Present: Chairperson Todd Myers, Todd Crotty, and Mike Jones, absent Edward Hayes-Hall. City Staff present – Mayor Dave Hemmer, Interim City Administrator Chad Abram and Matt Muchow from Vierbecher.
2. Certification of the open meeting law agenda requirements and approval of the agenda - Motion: Jones, Second: Crotty, Vote: 3-0
3. Approval – Minutes of the February 27, 2018 meeting – Motion: Myers Second: Jones Vote: 3-0

### **ACTION ITEMS**

4. DISCUSSION AND ACTION – PSA with Vierbecher for Marquette Road Construction Phase 2 and Villa Louis Boat Landing. A memo is included in the packet as well as a copy of the PSA. – Action: To approve and send to council PSA for Marquette Road construction Phase 2 and Villa Louis Boat Landing. Motion: Jones, Second, Crotty, Vote: 3-0
5. DISCUSSION AND ACTION – Establishing ATV/UTV routes within the City of Prairie du Chien. No action.
7. Adjournment(6:53 PM) – Motion: Myers, Second, Crotty, Vote: 3-0.

Submitted by Chad Abram, Interim City Administrator



## **MINUTES OF THE PERSONNEL COMMITTEE – March 6, 2018**

A meeting of the City of Prairie du Chien Personnel Committee was held on Tuesday, March 6, 2018 at 5:48 P.M. in City Hall.

### **GENERAL ITEMS TO BE ACTED UPON**

1. Call to Order & Roll Call – Karen Solomon (Chairperson) Nate Gilberts, and Heather Olson absent Edward Hayes-Hall. City staff also present: Mayor Dave Hemmer, City Administrator Chad Abram and Park and Recreation Director Michael Ulrich.
2. Certification of the open meeting law agenda requirements and approval of the agenda – Motion: Gilberts, Second: Olson, Vote: 3-0.
3. Approval of the minutes of the February 27, 2018. Motion: Gilberts, Second, Olson, Vote: 3-0.

### **ACTION ITEMS**

4. DISCUSSION AND ACTION – Discussion on Vacancy of Recreation Coordinator. No action taken.
5. ADJOURNMENT (6:19 P.M.) – Motion: Solomon, Second: Olson, Vote: 3-0.

Submitted by Chad Abram, Interim City Administrator

LAW OFFICES OF  
PETERSON, ANTOINE & PETERSON, S.C.

C. B. PETERSON [1892-1969]  
F. J. ANTOINE [1910-1997]  
LEARY E. PETERSON [1923-2015]  
MARK A. PETERSON  
THOMAS F. PETERSON

110 EAST HAYDN STREET  
P. O. BOX 430  
PRAIRIE DU CHIEN, WISCONSIN 53821  
PHONE NO. 608-326-6496  
FAX NO. 608-326-8070

March 15, 2018

To the Common Council of the City of Prairie du Chien, Crawford County, Wisconsin

Re: Transfer of Liquor License Issued to Susan K. Selch  
Trade Name: Sue Z's Bar

Enclosed herewith Class B Retail – Combo Liquor License issued to Susan K. Selch. This License is surrendered conditioned and in anticipation of its subsequent re-issuance of same to Curtis Roger Bender d/b/a New Spit & Whistle pursuant to the attached Offer to Purchase.

In the event said Liquor License is not re-issued to Curtis Roger Bender d/b/a New Spit & Whistle on or before the 23rd day of March, 2018, you are directed to return said License to Susan K. Selch.

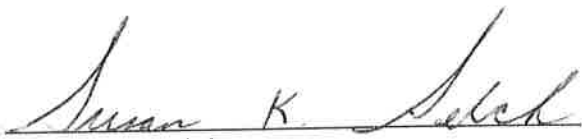
  
Susan K. Selch

Peoples State Bank, Seller as per the attached Offer to Purchase agrees to the surrender of said license subject to the terms and conditions above set forth.

  
Mark W. Forsythe

**City of Prairie du Chien  
County of Crawford  
State of Wisconsin  
Licenses**

WHEREAS, the City of Prairie du Chien, Crawford County, State of Wisconsin, has, upon application duly made, granted and authorized the issuance of the following Licenses:

Issued to: **SUSAN K. SELCH** PO BOX 54  
PRAIRIE DU CHIEN, WI 53821

Trade Name: **SUE Z'S BAR** 1000 S BEAUMONT RD  
PRAIRIE DU CHIEN, WI 53821

<u>License Type</u>	<u>License No</u>	<u>Effective</u>	<u>Expires</u>	<u>Fee</u>
<b>Class B Retail - Combo</b>	<b>2016 - 18</b>	<b>10/05/2016</b>	<b>6/30/2017</b>	<b>375.00</b>
Beer			75.00	
Liquor			300.00	
Publication fee:				4.00

WHEREAS, this license is subject to all resolutions, ordinances, regulations, and provisions as may be at any time imposed by the local governing body or any laws of the State of Wisconsin, and is subject to revocation as provided by law.

**Given under my hand and the Corporate Seal of the  
City of Prairie du Chien, County of Crawford,  
this 5th day of October, 2016.**

**Total fee:  
\$379.00**



**Barbara Elvert**

This license must be FRAMED and POSTED IN A CONSPICUOUS PLACE in the room where Fermented Malt Beverages and Intoxicating Liquors are sold or served.

3/20/2018

**Operator License**

**Business**

Kracheys BP  
DH BP North

**Last Name**

Dee  
White

**First Name**

Angela  
Dustin

Consent Agenda for Council Meeting Approval

Council Meeting: 03-20-2018

Event/Item/Person	Date	Applying For:	Person
Curtis R Bender dba New Spit & Whistle @ 1000 S Beaumont Rd	3/20/2018	Class B Beer & Class B Liquor Licenses	Curtis Bender
Kwik Trip #842	3/20/2018	Change of Agent to:	Grace K. Ferries

MEMO

TO: Prairie du Chien City Council

From: Street Dept. Superintendant Dan Titlbach

Date: March 15,2018

Subject: Storm Sewer Outlet on S. Main St. and W. Wisconsin St.  
Reattach separated 48" concrete culvert sections

Cost:	Rental of Crawford County Excavator with Operator @ \$86.00 per Hour approximately 16 hour's	\$1,376.00
	6 Eye bolt and tie rod	<u>\$275.00</u>
	Total	\$1,651.00

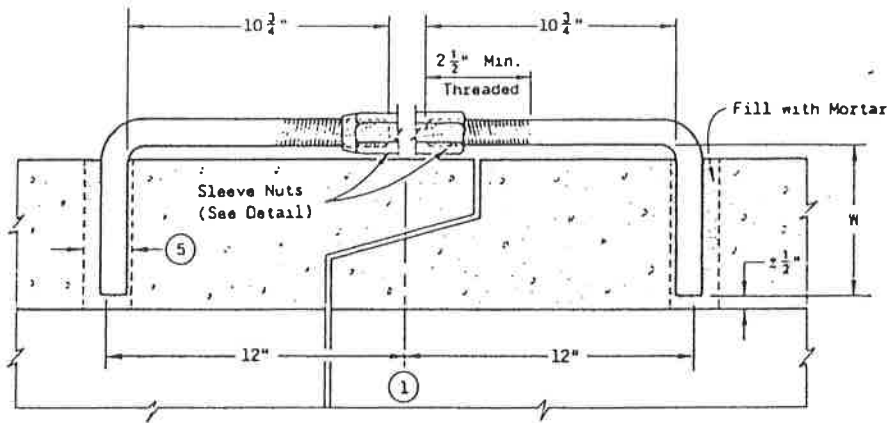

LONGITUDINAL SECTION

(JOINT TIES FOR 12" TO 108" DIA. CONCRETE PIPE)

ADJUSTABLE TIE ROD

ADJUSTABLE TIE ROD TABLE

PIPE DIAMETER	TIE ROD DIAMETER	D	L <sub>1</sub>	N	W
12-60	5/8	5/8	5	1/2	1 3/4
66-84	3/4	3/4	5	1/2	5
90-108	1	1	7	7/8	7 1/2

DIMENSIONS SHOWN ARE IN INCHES

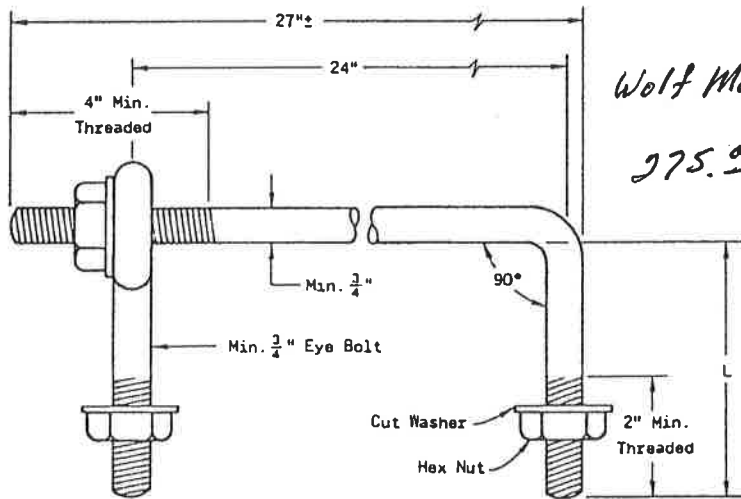

*Wolf Machine*  
*275.00*

EYE BOLT AND TIE ROD

(JOINT TIES FOR 18" TO 66" DIA. CONCRETE PIPE)

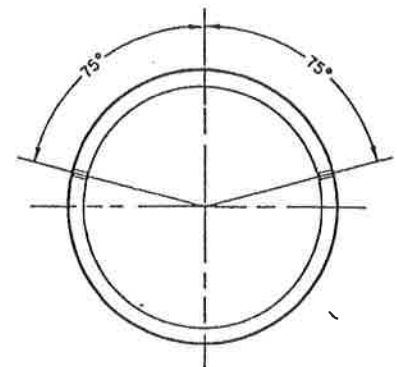

Placement of (2) Cast-in-Place inserts or holes during fabrication for pipe sections requiring Tie Rods

TRANSVERSE SECTION

TIED JOINTS FOR CULVERT PIPE

When it is desirable to tie end joints or intermediate pipe sections together, one of the above methods is usually used. These ties may be used on either pipe or box culverts.

The joints may be mortar, mastic or rubber gasket.

Joint ties may be made to other specifications.





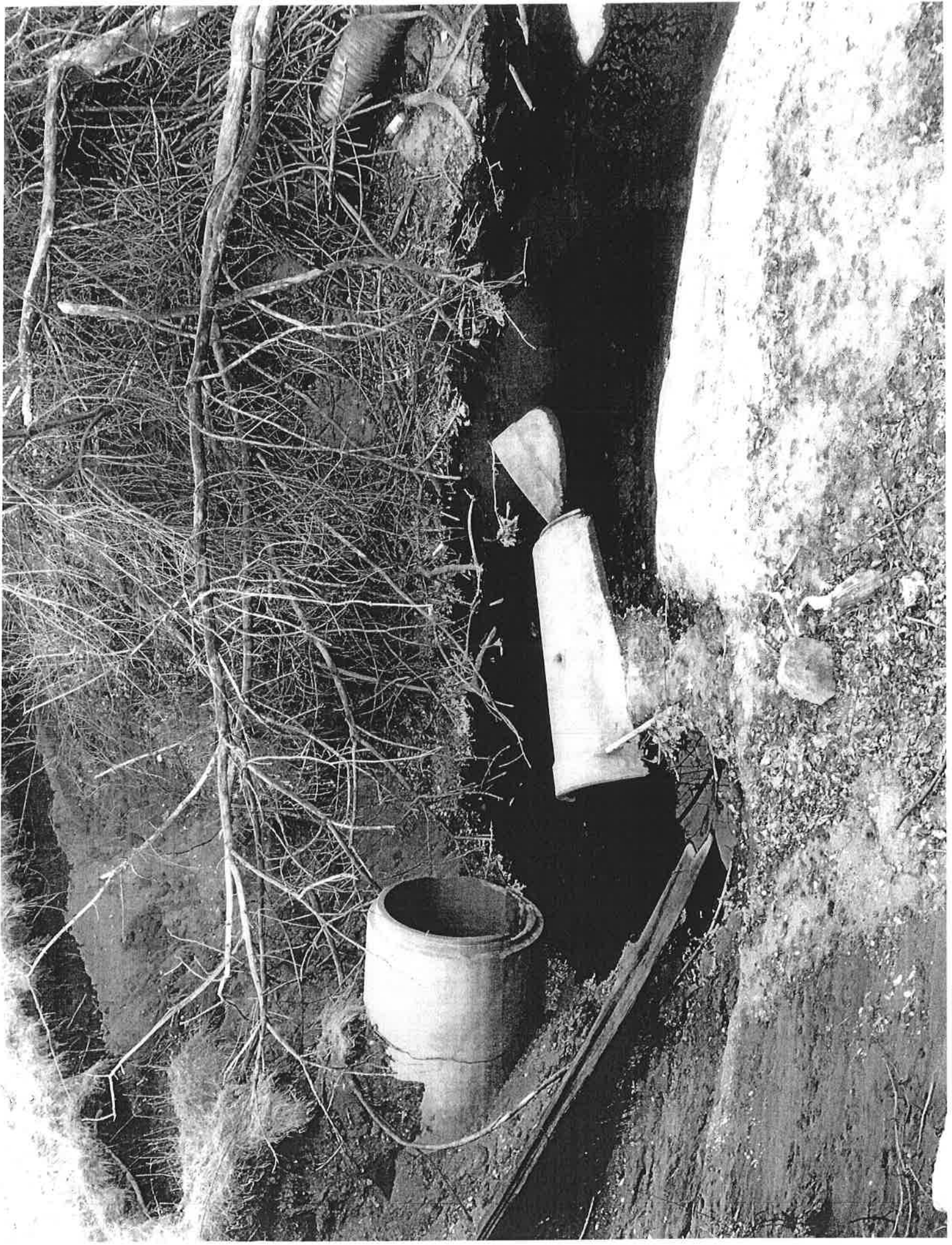

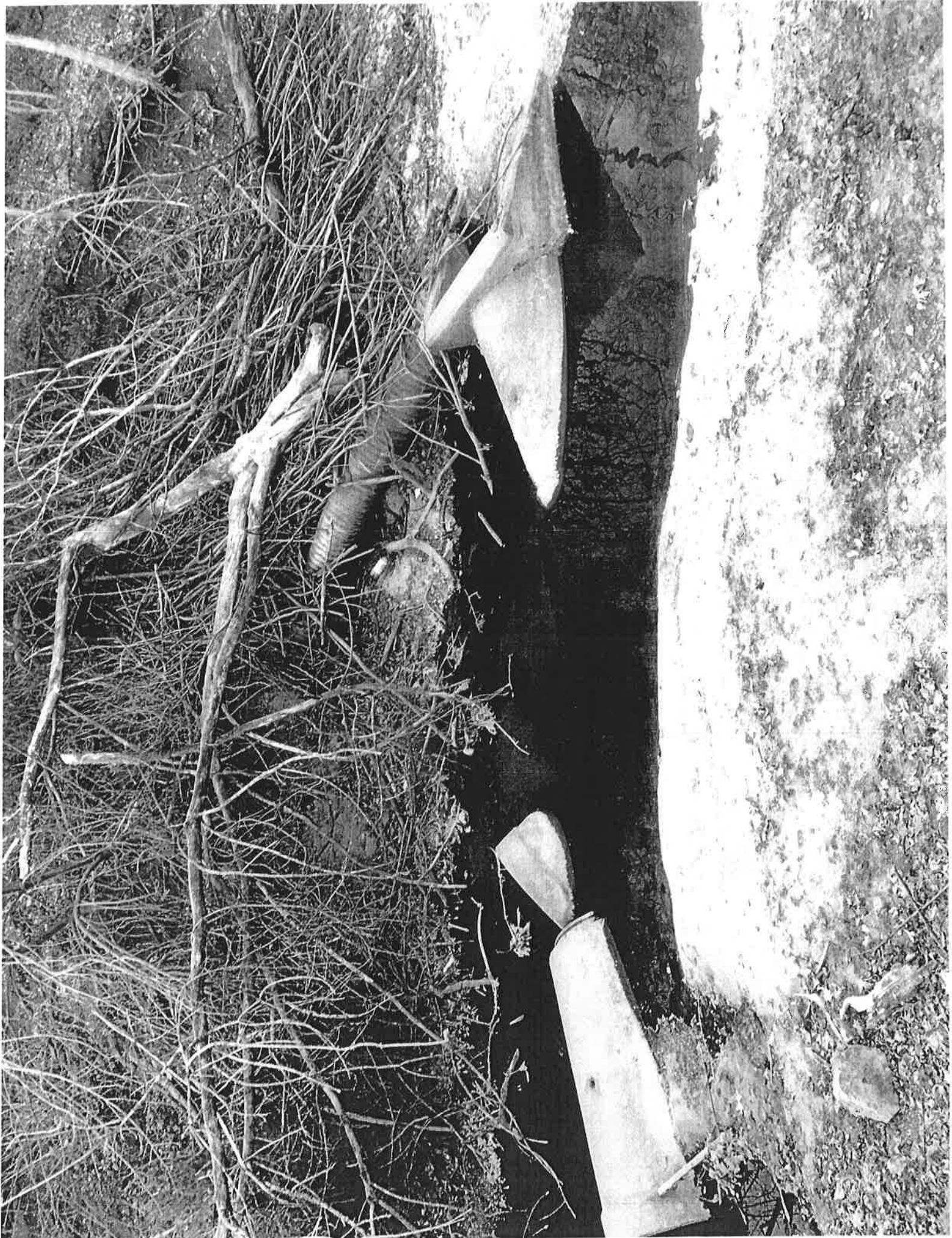



## NOTICE OF BID LETTING

The Board of Public Works for the City of Prairie du Chien will be accepting bids for:

- 1.) Bituminous Paving**
- 2.) Miscellaneous Curb & Gutter/Sidewalk Replacement**

Bidding documents may be examined at City Hall and obtained from Dan Titlbach, Street Supervisor, at 625 E. Washington St., Prairie du Chien, Wisconsin, 53821; (608) 326-2525; streets@prairieduchien-wi.gov.

Bids are to be written and received by the Street Supervisor Dan Titlbach at 214 East Blackhawk Avenue, PO Box 324, Prairie du Chien, Wisconsin 53821 on or before 2:00 p.m., Friday, April 6, 2018. Bid envelopes are to be marked "BID FOR (item being bid on)". Bids shall be opened and read aloud at 2:00 p.m. at City Hall on April 6, 2018.

The City of Prairie du Chien reserves the right to waive any irregularities which may or may not be in the City's best interest. The City reserves the right to accept or reject any and all bids, and may select the bid most advantageous to the City.

Dan Titlbach  
Street Department Superintendent

Publishing Dates: March 21<sup>st</sup> and March 26<sup>th</sup>, 2018

**TO:** Chad Abram  
**FROM:** Garth W. Frable  
**RE:** Proposals for Performing Mussel Survey  
**DATE:** March 15, 2018

A Wisconsin Department of Natural Resources requirement for the City's proposed expansion of the Villa Louis Boat Landing is to have a biological survey of the site done to determine if mussel species are present in the area that will be disturbed by the work. This is very specialized work requiring strict surveying protocols, divers, and detailed documentation.

The following three proposals were received.

	<b>Helm &amp; Associates</b>	<b>Endangered Resource Services, LLC</b>	<b>Daguna Consulting LLC</b>
Survey & Initial Report Cost	\$11,426	\$3,475	\$7,491

The City will recommend the selection of the proposal that is the lowest cost and meets all WDNR requirements.

Project 1661-05-76 and 1991-05-86

STH 35 Marquette Street, Prairie du Chien

Activity Name	Original Start	Finish
Marquette Street (Prairie du Chien)	4/11/2018	10/31/2018
Stage 1 - Wells St to Money St	4/11/2018	6/29/2018
Traffic Control	4/11/2018	4/11/2018
Initial Erosion Control Mdb	4/11/2018	4/11/2018
Clear and Grub	4/11/2018	4/11/2018
Pavement Removals	4/11/2018	4/11/2018
Water Utility Work and Temp Bypasses	4/11/2018	4/11/2018
Sanitary Sewer Utility Work	4/11/2018	4/11/2018
Install Storm Sewer	4/11/2018	4/11/2018
Grading Operations	4/11/2018	4/11/2018
Place 1 1/4" Agg Base	4/11/2018	4/11/2018
Trim Agg Base	4/11/2018	4/11/2018
Machine Paving Operations	4/11/2018	4/11/2018
Concrete Cure Time	4/11/2018	4/11/2018
Curband Gutter Paving	4/11/2018	4/11/2018
Erosion Control Mdb - Inlet Protection	4/11/2018	4/11/2018
Install Electrical Conduits	4/11/2018	4/11/2018
Grades and Pave Sidewalks	4/11/2018	4/11/2018
Grads/Place Agg base on Bike Path	4/11/2018	4/11/2018
Asphalt Pave Path, Driveways and Tie-Ins	4/11/2018	4/11/2018
Install Chain Link Fence - Stage 1	4/11/2018	4/11/2018
Complete Ped Ramp	4/11/2018	4/11/2018
Erosion Control Mdb - Restoration Stage 1	4/11/2018	4/11/2018
Complete Lighting Operations	4/11/2018	4/11/2018
Install Signs	4/11/2018	4/11/2018
Stripping - Epoxy	4/11/2018	4/11/2018
Stage 2 - Champion St to Wells St	6/29/2018	8/11/2018
Traffic Control	6/29/2018	6/29/2018
Initial Erosion Control	6/29/2018	6/29/2018
Pavement Removals	6/29/2018	6/29/2018
Sewer Utility Work	6/29/2018	6/29/2018
Storm Sewer Installation	6/29/2018	6/29/2018
Grading	6/29/2018	6/29/2018
1 1/4" Base Placement	6/29/2018	6/29/2018
Trim Agg Base	6/29/2018	6/29/2018
Machine Paving Operations	6/29/2018	6/29/2018
Concrete Cure Time	6/29/2018	6/29/2018
Curband Gutter Paving	6/29/2018	6/29/2018
Erosion Control Mdb - Inlet Protection	6/29/2018	6/29/2018
Install Electrical Conduits behind curb	6/29/2018	6/29/2018
Sidewalk Paving	6/29/2018	6/29/2018
Grads and Shape Blue Path	6/29/2018	6/29/2018
Asphalt Pave Bike Path, Driveways, and Tie-Ins	6/29/2018	6/29/2018
Complete Ped Ramp Concrete	6/29/2018	6/29/2018

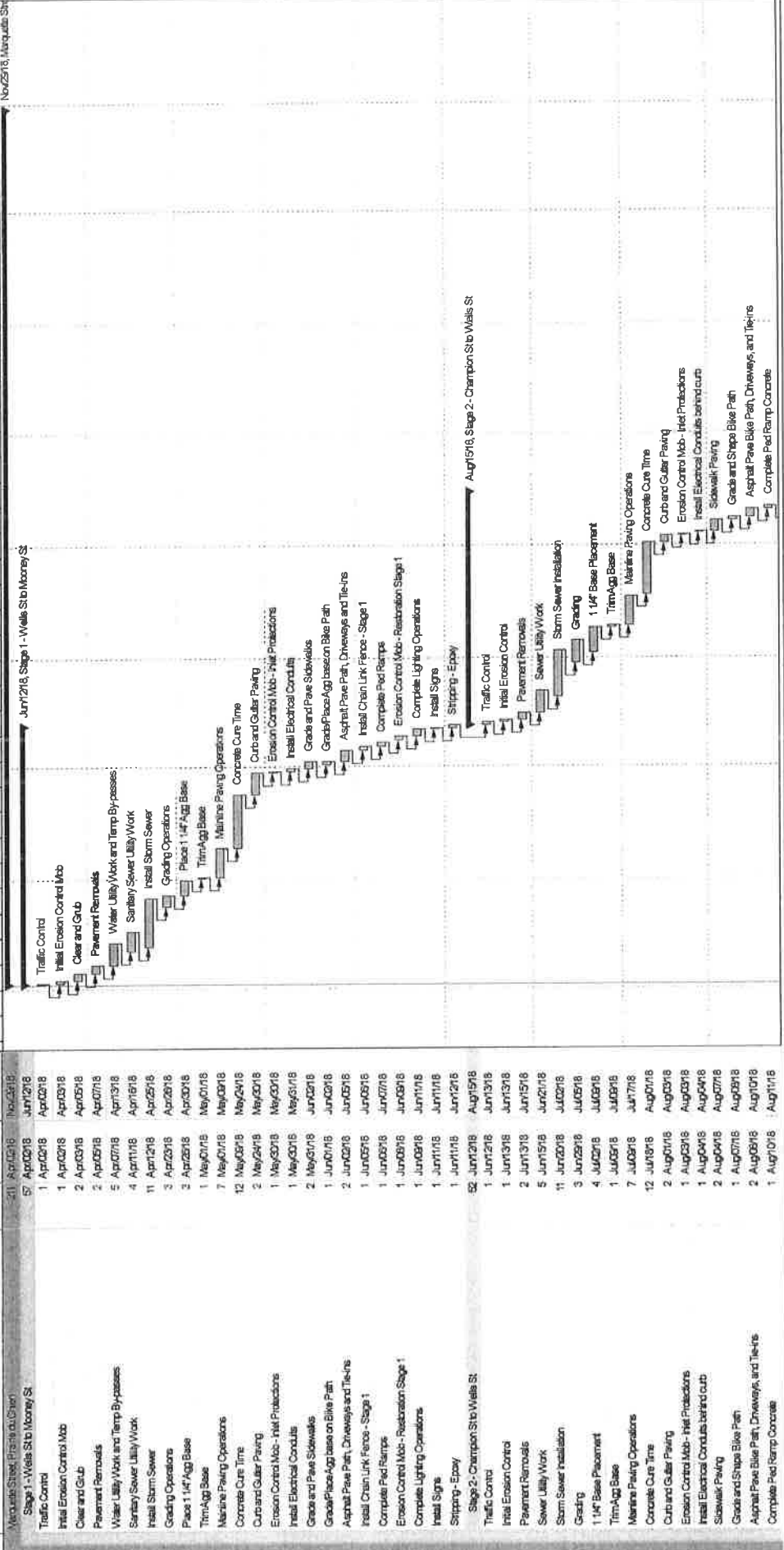



Gerke Excavating, Inc  
Ron Overlien

Activity Name	Original Start	Finish
Marquette Street (Prairie du Chien)	4/11/2018	10/31/2018
Stage 1 - Wells St to Money St	4/11/2018	6/29/2018
Traffic Control	4/11/2018	4/11/2018
Initial Erosion Control Mdb	4/11/2018	4/11/2018
Clear and Grub	4/11/2018	4/11/2018
Pavement Removals	4/11/2018	4/11/2018
Water Utility Work and Temp Bypasses	4/11/2018	4/11/2018
Sanitary Sewer Utility Work	4/11/2018	4/11/2018
Install Storm Sewer	4/11/2018	4/11/2018
Grading Operations	4/11/2018	4/11/2018
Place 1 1/4" Agg Base	4/11/2018	4/11/2018
Trim Agg Base	4/11/2018	4/11/2018
Machine Paving Operations	4/11/2018	4/11/2018
Concrete Cure Time	4/11/2018	4/11/2018
Curband Gutter Paving	4/11/2018	4/11/2018
Erosion Control Mdb - Inlet Protection	4/11/2018	4/11/2018
Install Electrical Conduits	4/11/2018	4/11/2018
Grades and Pave Sidewalks	4/11/2018	4/11/2018
Grads/Place Agg base on Bike Path	4/11/2018	4/11/2018
Asphalt Pave Path, Driveways and Tie-Ins	4/11/2018	4/11/2018
Install Chain Link Fence - Stage 1	4/11/2018	4/11/2018
Complete Ped Ramp	4/11/2018	4/11/2018
Erosion Control Mdb - Restoration Stage 1	4/11/2018	4/11/2018
Complete Lighting Operations	4/11/2018	4/11/2018
Install Signs	4/11/2018	4/11/2018
Stripping - Epoxy	4/11/2018	4/11/2018
Stage 2 - Champion St to Wells St	6/29/2018	8/11/2018
Traffic Control	6/29/2018	6/29/2018
Initial Erosion Control	6/29/2018	6/29/2018
Pavement Removals	6/29/2018	6/29/2018
Sewer Utility Work	6/29/2018	6/29/2018
Storm Sewer Installation	6/29/2018	6/29/2018
Grading	6/29/2018	6/29/2018
1 1/4" Base Placement	6/29/2018	6/29/2018
Trim Agg Base	6/29/2018	6/29/2018
Machine Paving Operations	6/29/2018	6/29/2018
Concrete Cure Time	6/29/2018	6/29/2018
Curband Gutter Paving	6/29/2018	6/29/2018
Erosion Control Mdb - Inlet Protection	6/29/2018	6/29/2018
Install Electrical Conduits behind curb	6/29/2018	6/29/2018
Sidewalk Paving	6/29/2018	6/29/2018
Grads and Shape Blue Path	6/29/2018	6/29/2018
Asphalt Pave Bike Path, Driveways, and Tie-Ins	6/29/2018	6/29/2018
Complete Ped Ramp Concrete	6/29/2018	6/29/2018

Summary

- Remaining Level of Effort
- Actual Level of Effort
- Actual Work
- Remaining Work
- Critical Remaining Work
- Milestone

Project 1661-05-76 and 1991-05-86

STH 35 Marquette Street, Prairie du Chien

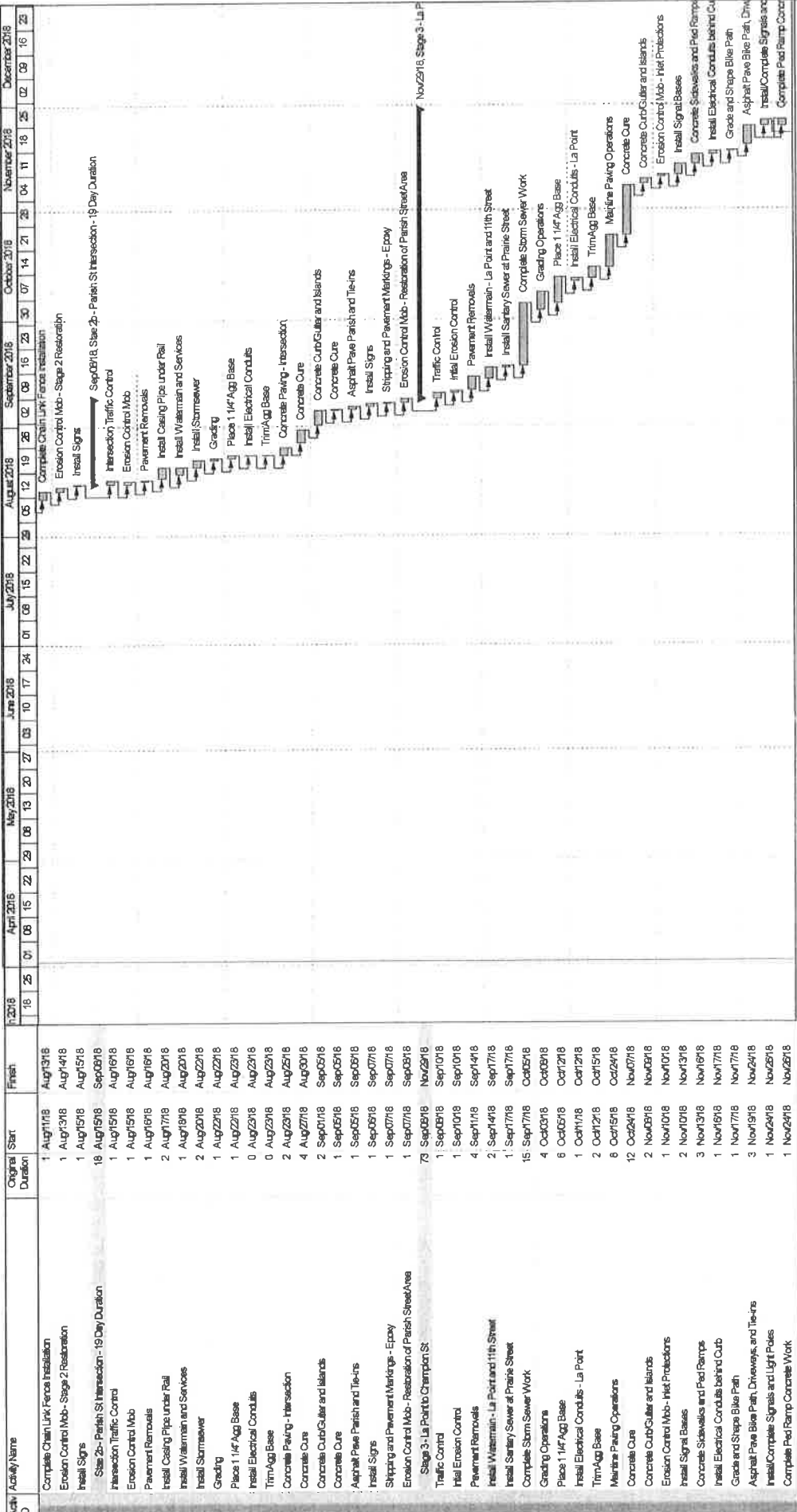

Activity Name	Original Start	Finish
Complete Chain Link Fence Installation	1 Aug/1/18	Aug/13/18
Erosion Control Mob - Stage 2 Restoration	1 Aug/13/18	Aug/14/18
Install Signs	1 Aug/15/18	Aug/15/18
Stage 2a - Parish St Intersection - 19 Day Duration	18 Aug/15/18	Sep/03/18
Intersection Traffic Control	1 Aug/15/18	Aug/16/18
Erosion Control Mob	1 Aug/15/18	Aug/16/18
Pavement Removals	1 Aug/16/18	Aug/16/18
Install Casing Pipes Under Rail	1 Aug/17/18	Aug/20/18
Install Walkman and Services	1 Aug/19/18	Aug/20/18
Install Stormsewer	2 Aug/20/18	Aug/22/18
Grading	1 Aug/22/18	Aug/22/18
Place 1 1/4' Agg Base	1 Aug/22/18	Aug/23/18
Install Electrical Conduits	1 Aug/23/18	Aug/23/18
Trim Agg Base	0 Aug/23/18	Aug/23/18
Concrete Paving - Intersection	2 Aug/23/18	Aug/25/18
Concrete Cure	4 Aug/27/18	Aug/30/18
Concrete Curb/Gutter and Islands	2 Sep/01/18	Sep/05/18
Concrete Cure	1 Sep/05/18	Sep/05/18
Asphalt Pave Parish and Tie-ins	1 Sep/05/18	Sep/05/18
Install Signs	1 Sep/05/18	Sep/07/18
Shipping and Pavement Markings - Epoxy	1 Sep/07/18	Sep/07/18
Erosion Control Mob - Restoration of Parish Street Area	1 Sep/07/18	Sep/08/18
Stage 3 - La Pointe to Champaign St	79 Sep/09/18	Nov/29/18
Traffic Control	1 Sep/09/18	Sep/10/18
Initial Erosion Control	1 Sep/10/18	Sep/10/18
Pavement Removals	4 Sep/11/18	Sep/14/18
Install Walkman - La Pointe and 11th Street	2 Sep/14/18	Sep/17/18
Install Sanitary Sewer at Prairie Street	1 Sep/17/18	Sep/17/18
Complete Storm Sewer Work	15 Sep/17/18	Oct/05/18
Grading Operations	4 Oct/05/18	Oct/21/18
Place 1 1/4' Agg Base	1 Oct/11/18	Oct/12/18
Install Electrical Conduits - La Pointe	2 Oct/12/18	Oct/15/18
Trim Agg Base	6 Oct/15/18	Oct/24/18
Machine Paving Operations	8 Oct/24/18	Oct/24/18
Concrete Cure	12 Oct/24/18	Nov/07/18
Concrete Curb/Gutter and Islands	2 Nov/08/18	Nov/08/18
Erosion Control Mob - Inlet Protections	2 Nov/10/18	Nov/13/18
Install Sign Bases	3 Nov/13/18	Nov/16/18
Concrete Sidewalks and Ped Ramps	1 Nov/16/18	Nov/17/18
Install Electrical Conduits behind Curb	1 Nov/17/18	Nov/17/18
Grade and Shape Bike Path	3 Nov/19/18	Nov/24/18
Asphalt Pave Bike Path, Driveways, and Tie-ins	1 Nov/24/18	Nov/25/18
Install Complete Signals and Light Poles	1 Nov/24/18	Nov/25/18
Complete Ped Ramp Concrete Work	1 Nov/24/18	Nov/25/18

GERKE  
Excavating, Inc.

Gerke Excavating, Inc  
Ron Overlien

